

The CRM 200S-RF is a single element boundary layer through table condenser microphone, with a built-in mechanism that will allow the user to make the microphone disappear without having to physically remove it from the table. This is achieved by simply pressing the top of the microphone downwards until it locks; then by pressing the microphone again it will raise itself back to its original position above the surface of the table. Engineered in high quality brass with built in shock mount and RF filter.

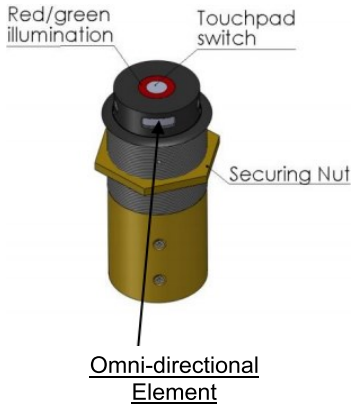

- Omnidirectional polar pattern
- Electronic capacitive touch switch facilitating click / pop free muting of a microphone.
- Must be used in conjunction with a digital signal processor (dsp).
- Power requirements 12Vdc from regulated power supply.
- 500mm 5 way ribbon color coded cable, terminated with an RJ45 connector and supplied with an RJ45 coupler which allows connection via RJ12 or RJ45 connection back to the DSP.
- Supplied with 2m (6.6ft) 2 core + screen audio cable and 1 x grey 2 core cable for internal reed switch
- Satin Nickel (CRM 200NS-RF) or Black Nextel (CRM 200S-RF) finish
- Fitted with a magnetic reed switch designed to prevent unwanted feedback from retracted microphones on power up. The switch contact is closed (ON) when the microphones are in the raised position and open (OFF) when retracted.

This is not designed to be used for privacy muting.

Installation Guide

- 1) Drill a 58mm (2.25”) hole through the table see fig A.
- 2) Remove the nut and fit the CRM 200S-RF through the 58mm (2.25”) hole see fig B.
- 3) Replace nut and tighten to the underside of the table see fig C.
- 4) Connections : Red Phase +, White Phase – and screen Ground.
- 5) Switch wiring connections:

Cable colour	Function	RJ 45 Pin number
Red	Red LED	2
Blue	-ve switch	3
Brown	+ve 12V dc switch	4
Yellow	Switch Logic control	5
Green	Green LED	6



Fig A

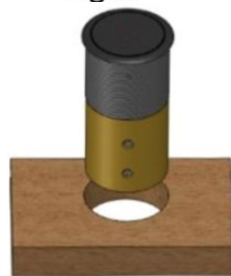

Fig B



Fig C

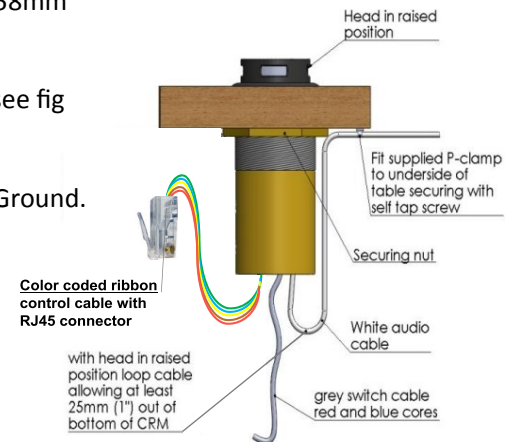

Fig D

Please note programming will be needed on the DSP side to allow the microphone to be muted.

- 6) Grey 2 core (red and blue wires) is to be used for remote switching, screen is not used. Also note switch is open circuit when the mic is down. Using p-clamps provided fix cables to the underside of the table ensuring there is sufficient slack in the cable loom for the mic to operate See fig D.