

# Connected to Crestron PROCESSOR \*

(2-Series, 3-Series, DMPS, MPC, MPS, Adagio)

(2 & 3-Series Control Cards)



- ClockAudio Device**
- >CH32
  - >TS001
  - >CS Series with switch
  - >SM80S
  - >S80
  - >CRM202S-RF

Red LED = Red cable  
 Ground/-Ve switch = Blue cable  
 +Ve 12Vdc = Brown cable  
 Switch logic Control = Yellow cable  
 Green LED = Green cable

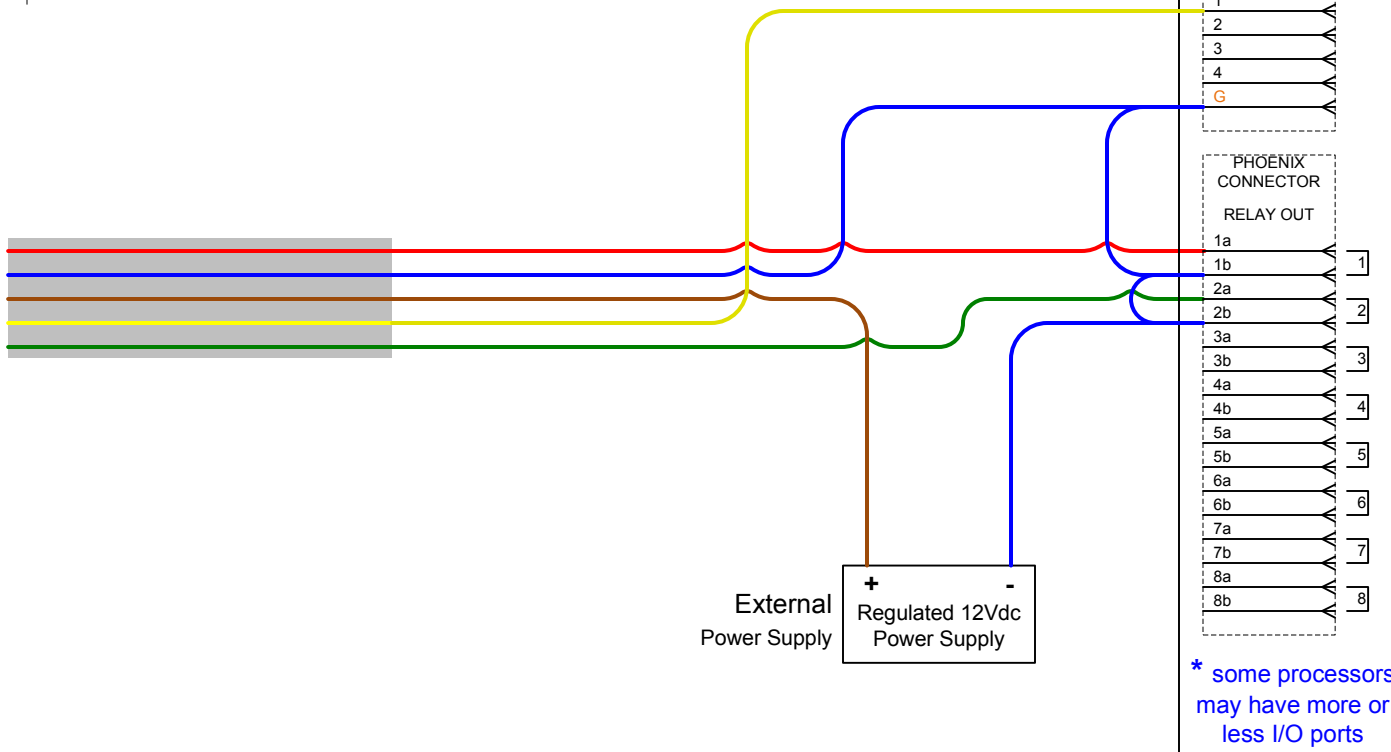

\* some processors may have more or less I/O ports

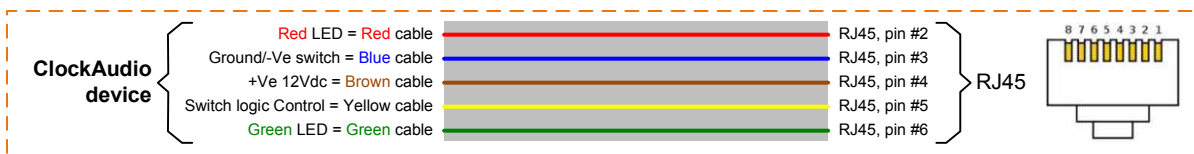

-To switch the halo light between red and green, 2 different relays are required.  
 -This document assumes the reader has knowledge of Crestron programming.

# Connected to Crestron ST-IO

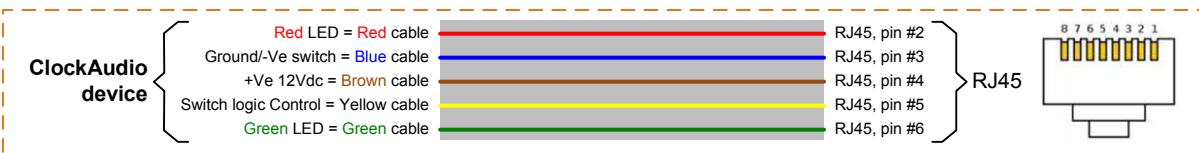
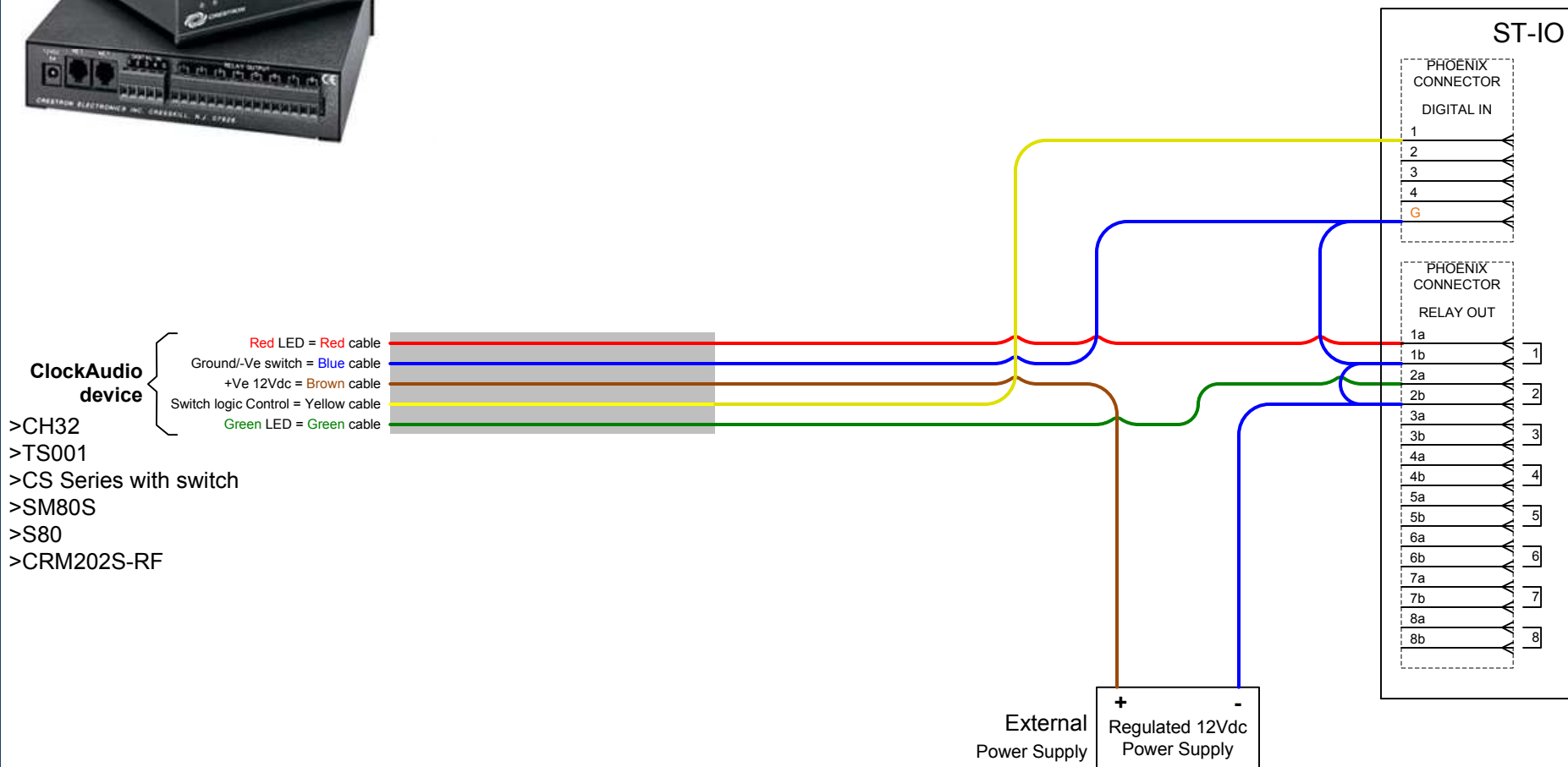

-To switch the halo light between red and green, 2 different relays are required.  
-This document assumes the reader has knowledge of Crestron programming.

# Connected to Crestron CNPI-48



- ClockAudio device**
- >CH32
  - >TS001
  - >CS Series with switch
  - >SM80S
  - >S80
  - >CRM202S-RF

Red LED = Red cable  
 Ground/-Ve switch = Blue cable  
 +Ve 12Vdc = Brown cable  
 Switch logic Control = Yellow cable  
 Green LED = Green cable

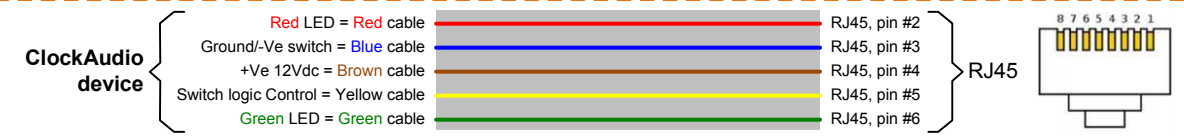
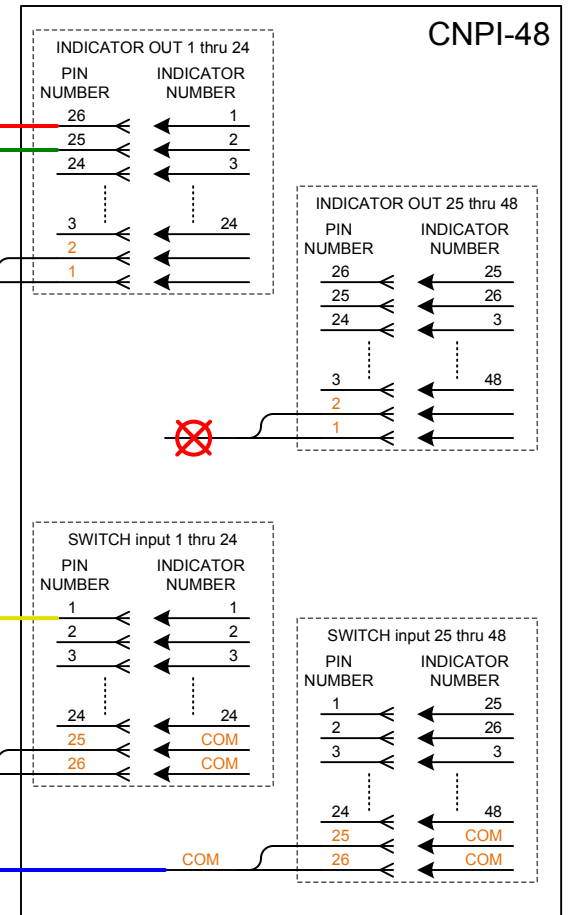
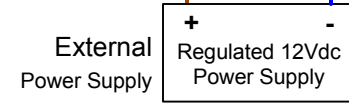

-To switch the halo light between red and green, 2 different relays are required.  
 -This document assumes the reader has knowledge of Crestron programming.



## Connected to Crestron VersiPort

(CNXIO-16, C3IO-16 cards, Din-IO8)

**NOTE #1:**  
I/O Setup: **Digital Input**  
Pull-up Resistor: **Enable**

**NOTE #2:**  
I/O Setup: **Digital Output**  
Pull-up Resistor: **Disable**

**ClockAudio Device**

- >CH32
- >TS001
- >CS Series with switch
- >SM80S
- >S80
- >CRM202S-RF

Red LED = Red cable  
 Ground/-Ve switch = Blue cable  
 +Ve 12Vdc = Brown cable  
 Switch logic Control = Yellow cable  
 Green LED = Green cable

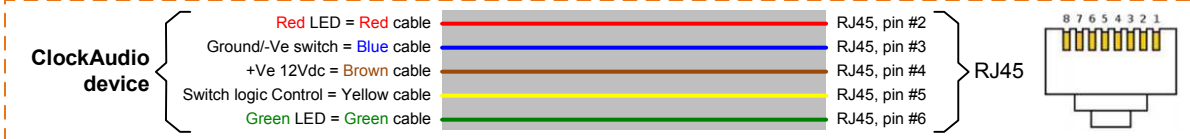
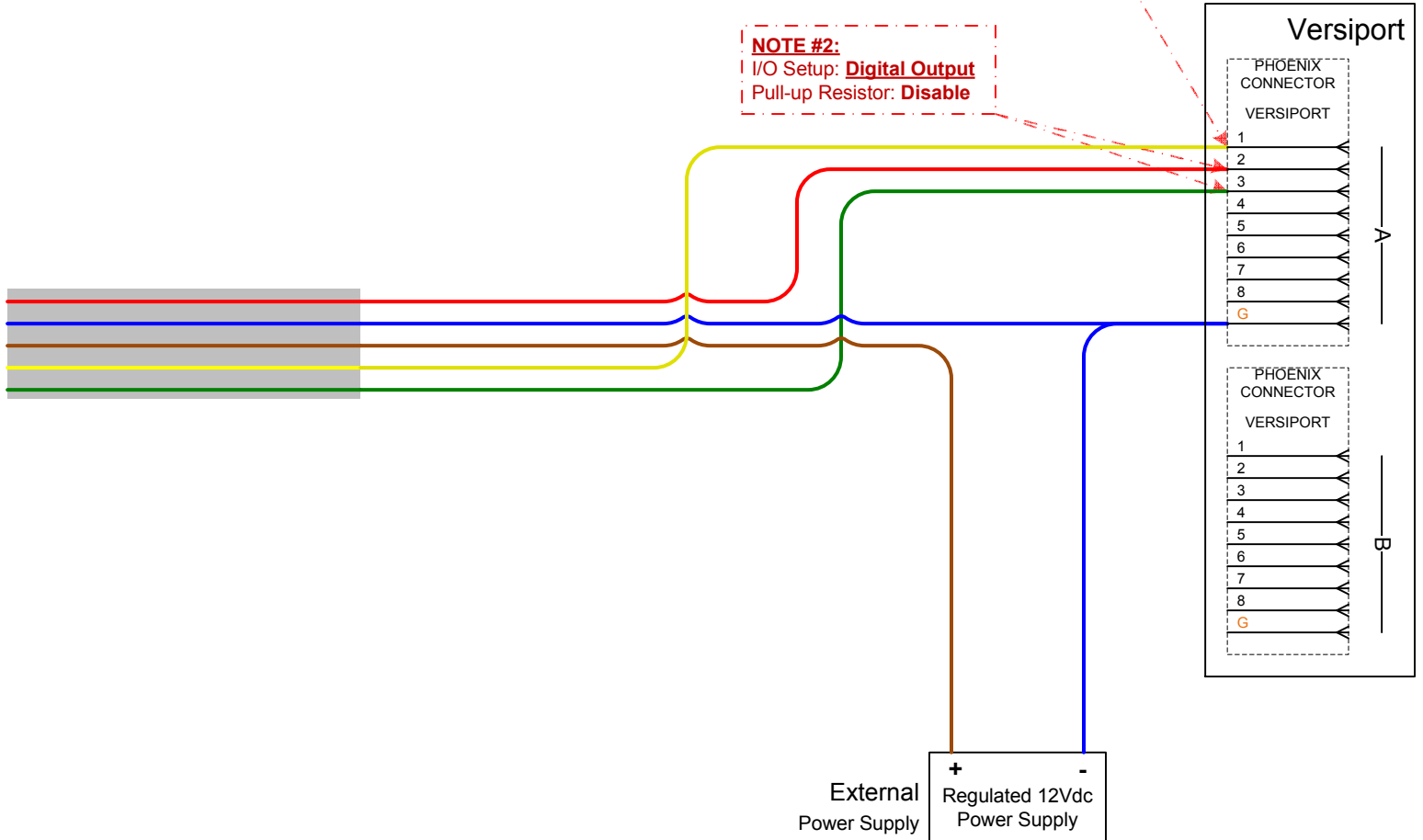

-To switch the halo light between red and green, 2 different relays are required.  
-This document assumes the reader has knowledge of Crestron programming.