



CDT100 MKII

Clockaudio Dante Transporter

User Manual



Clearly different.™

Clockaudio Ltd.

Address: Unit C, Wellington Gate, Silverthorne Way, Waterlooville, Hampshire PO7 7XY, UK
Tel: +44(0)23 9225-1193 Fax: +44(0)23 9225 1201
Email: info@Clockaudio.co.uk

Clockaudio North America Inc.

Address: 2891, du Meunier, Unit 103, Vaudreuil-Dorion, QC, Canada J7V 8P9
Toll Free: 1-888-424-9797 Tel: 450-424-9797 Fax: 450-424-3660
Email: info@clockaudio.com

Clockaudio PTE Ltd.

Address: BizTech Centre, Unit # 01-02, 627A Aljunied Road, Singapore, 389842
Tel: +65 67484738 Fax: +65 67484428
Email: info@clockaudio.com.sg

IMPORTANT SAFETY INSTRUCTIONS



TO REDUCE THE RISK OF FIRE OR ELECTRIC SHOCK, DO NOT EXPOSE THIS APPARATUS TO RAIN OR MOISTURE.

1. Read these instructions.
2. Keep these instructions.
3. Heed all warnings.
4. Follow all instructions.
5. Do not use this apparatus near water.
6. Clean only with a dry cloth.
7. Do not block any ventilation openings. Install in accordance with the manufacturer's instructions.
8. Do not install near any heat sources such as radiators, heat registers, stoves, or other apparatus (including amplifiers) that produce heat.
9. Do not defeat the safety purpose of the polarized or grounding-type plug. A polarized plug has two blades with one wider than the other. A grounding type plug has two blades and third grounding prong. The wider blade or the third prong is provided for your safety. If the provided plug does not fit into your outlet, consult an electrician for replacement of the obsolete outlet.
10. Protect the power cord from being walked on or pinched particularly at plugs, convenience receptacles, and the point where they exit from the apparatus.
11. Only use attachments/accessories as specified by Clockaudio.
12. Refer all servicing to qualified service personnel. Servicing is required when the apparatus has been damaged in any way, such as power-supply cord or plug is damaged, liquid has been spilled or objects have fallen into the apparatus, if the apparatus has been exposed to rain or moisture, does not operate normally or has been dropped.
13. This apparatus shall be connected to a mains socket outlet with a protective earthing connection.
14. If rack mounting, provide adequate ventilation. Equipment may be located above or below this apparatus but some equipment (like large power amplifiers) may cause an unacceptable amount of hum may generate too much heat and degrade the performance of this apparatus.

At the end of the life of this equipment, dispose of equipment according to local regulations



LIMITED ONE YEAR WARRANTY

The equipment is warranted for one year from date of purchase from Clockaudio against defects in materials or workmanship.

This warranty does not cover equipment which has been abused or damaged by careless handling or shipping.

This warranty does not apply to used or demonstrator equipment.

Should any defect develop, Clockaudio will, at our option, repair or replace any defective parts without charge for either parts or labor.

If Clockaudio cannot correct the defect in the equipment, it will be replaced at no charge with a new item. Clockaudio will pay for the cost of returning the replacement equipment to you.

This warranty applies only to items returned to Clockaudio, shipping costs prepaid, within one year from the date of purchase.

Note:

This equipment has been tested and found to comply with the limits for a Class A digital device, pursuant to Part 15 of the FCC Rules and EN55022.

These limits are designed to provide reasonable protection against harmful interference when the equipment is operated in a commercial environment.

This equipment generates, uses, and can radiate radio frequency energy and, if not installed and used in accordance with the instruction manual, may cause harmful interference to radio communications.

Operation of this equipment in a residential area is likely to cause harmful interference, in which case the user will be required to correct the interference at his own expense.

Contents

1 – Overview	5
2 – Device Features	6
3 - Mounting	7
4 – Connections	8
4.1 – Input from a Balanced Source.....	8
4.2 – TS Port Pinout	9
5 – Dante Daisy Chaining	10
6.1 – Daisy Chain Illustration - Example 1.....	11
6.2 – Daisy Chain Illustration - Example 2.....	12
6 – Device Configuration	13
6.1 – IP Address Setup	13
7 – Recommended microphone placement	14
8 – Architect Specifications	15

1 - Overview

The CDT100 MKII four input Dante interface is the ideal interface for adding mic inputs to a Dante system. The addition of logic inputs and outputs allows easy interfacing with logic buttons and RGB LEDs.

The small form factor to the CDT 100 allows them to be close to the microphones, minimizing interference-prone analog wiring.

CDT100 MKII Features:

New RGB LED control for all Clockaudio RGB LED touch switches.

Now Dante and AES67 compatible.

2 new logic input pins on each TS ports (pin 1 and 8).

Easy to install with under table mounting flanges.

Audio and control signals transported over a single network cable.

4 balanced mic inputs using 3-pin terminal block connectors .

Can provide +48V phantom power to each mic inputs.

Powered by an external regulated +12VDC power supply (sold separately).

The 4 TS (Touch Switch) connections are fully backward compatible to all previous Clockaudio Bicolor touch switches.

The ARM-C port provides direct connection to the ARM motorized microphone controller or CCRM4000.

The CDT 100 MKII has two network connections to allow Dante Daisy Chaining (DDC).

DDC further simplifies system infrastructure wiring by allowing multiple CDT100 MKII's to use a single CAT 5 home run connection to a network switch.

Power can also be daisy chained, up to 6 units using our optional regulated 12V 5A power supply.

Compatible with any Dante or AES67 capable audio DSP.

The CDT 100 MKII can be controlled and monitored with 3rd party control modules using direct UDP messages or ConMon.

Parameters that can controlled includes:

1. Phantom Power On/Off
2. ARM-C Up/Down
3. LED Status and Brightness level
4. Button Status

Download the AMX and Creston interface modules and application notes from the CDT100 product / Technical Downloads section of the website www.clockaudio.com.

Please consult the Logic compatibility chart on our website for other DSP and control systems.

Refer to the manufacturer website for other control systems modules availability.

2 – Device Features

Figure 1 - CDT100 MKII front panel



Figure 2 - CDT100 MKII back panel

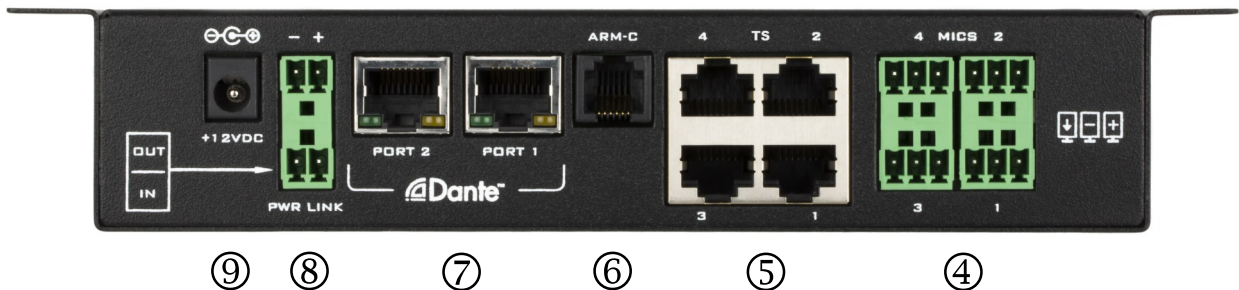

- ① Power LED.
- ② Reset Button (recessed).
- ③ Address Select (unused).
- ④ 4 Balanced microphone inputs with phantom power.
- ⑤ 4 TS control inputs ports. Connects directly to all Clockaudio control devices. Now with RGB LED support.
- ⑥ ARM-C controller direct connection.
- ⑦ 2 Dante Ethernet interface connector and indicators, up to six units may be daisy chained.
- ⑧ Daisy chain power input and output, up to six units may be daisy chained.
- ⑨ Power Socket - Use with optional 12V DC regulated supply only.

3 – Mounting

Installation of the CDT100 MKII is very straight forward.

It is recommended that the unit be secured to a flat surface with a screw through each mounting flange.

Dimensions for mounting are show in the Figure 9 below.

Use a No. 6 screw of a type and size that is applicable to the surface to which the CDT100 MKII will be attached.

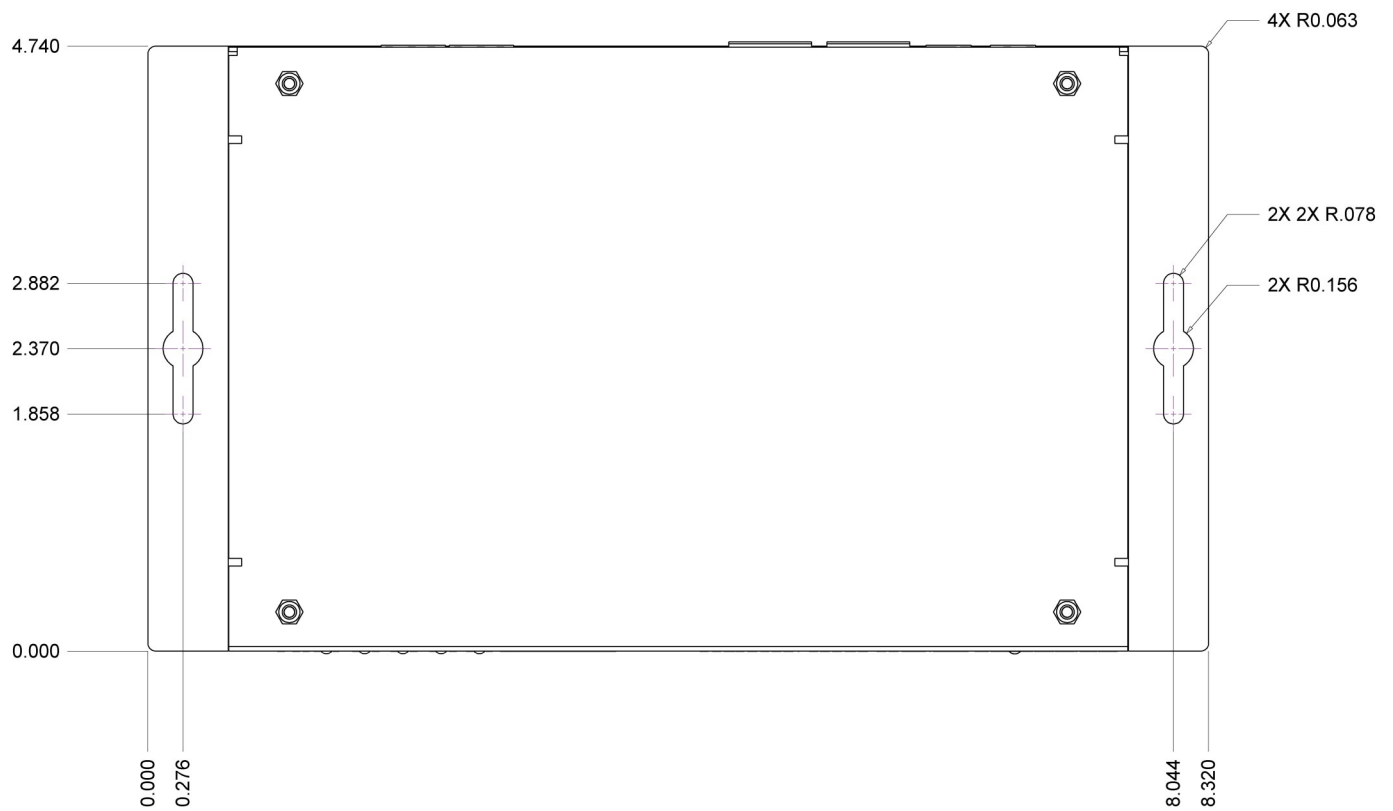

Figure 3 - Mounting Information

4 - Connections

All connections to the CDT100 MKII should be made before the power is applied.

- Connect audio sources to the balanced inputs.
- Connect touch switches and ARM-Controller
- Connect either Dante I/F port to a spare port on the Dante network switch using a CAT 5 cable.

When powering, using an optional external supply:

Attach the power supply to the power input jack and then power up the external supply.

If all steps are performed correctly, the power light on the front should be lit.
There may also be some activity on the CDT100 MKII Dante I/F LED indicators.

With no Dante network, both LEDs will remain off.

If an active connection is made, both LEDs will come on and if there is network activity, the yellow LED will flash.

4.1 - Input from a Balanced Source

The CDT 100 MKII accepts balanced microphones.

Refer to the following diagram and instructions for connecting Clockaudio microphones.

Professional grade audio cabling is recommended to achieve the best audio performance throughout the system.

- Connect positive output to positive input, negative output to negative input
- Connect the grounds together through the cable shield.

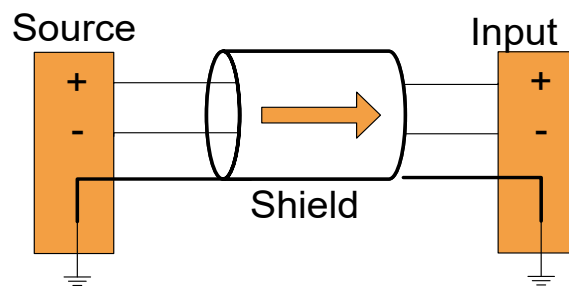
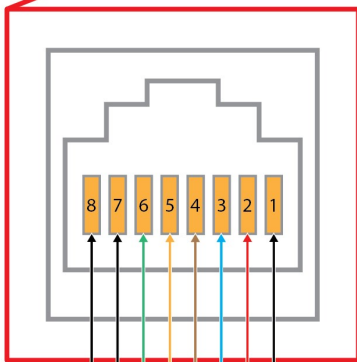
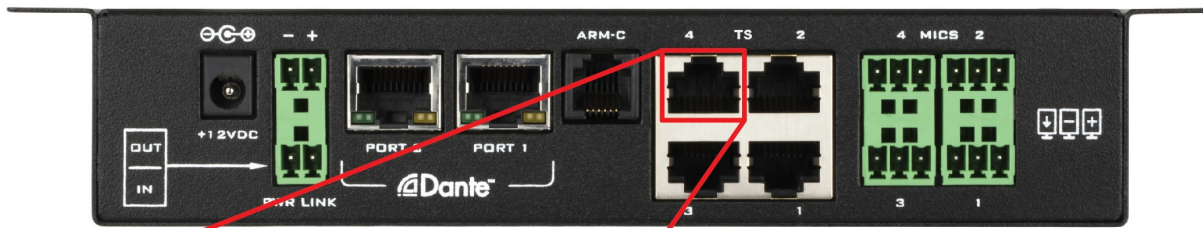

Figure 4 - Balanced Source Connection

4.2 – TS Ports Pinout



Pin out of the TS ports of the CDT100 MKII

- Pin #1, #5 & #8 are Switch Logic Inputs (GPIOs). These are pins that the DSP or control system reads the Hi/Low status and reacts as programmed (3.3V, switch for Clockaudio ctrl devices is Pin #5)
- Pin #2, #6 & #7 act as GPIO Outputs or relays/contact closures, that ground to Pin #3 , the common ground.
- Pin #3 is the Common Ground
- Pin #4 is the 12V supply for LED power and switch operation Maximum Power Output 50mA

1- Logic Input (this Pin supplies 3.3 Volts as a logic high) REED Switch of CRM microphone

2- Negative (-) lead for **Red** LEDs on Clockaudio device

3- Common Ground (LEDs & Switch operation) & REED Switch ground

4- 12 Volt (+) supply for Clockaudio control device's LEDs & Switch operation

5- **Logic Input** (this Pin supplies 3.3 Volts as a logic high)

6- Negative (-) lead for **Green** LEDs on Clockaudio device

7- Negative (-) lead for **Blue** LEDs on Clockaudio device

8- Logic Input (this Pin supplies 3.3 Volts as a logic high) User Defined Logic Input

5 – Dante Daisy Chaining

Overview:

A unique feature of the CDT100 MKII is its ability to allow daisy chaining of devices. This allows CDT100 MKII units in close proximity to one another to utilize a single home run of Ethernet cable back to the switch thus saving on installation costs.

Daisy chaining simply requires the new device be connected to the spare Ethernet port of the last CDT100 MKII device in the current chain.

Not only can the Ethernet connection be daisy chained, power can also be daisy chained too by connecting the daisy chain power output on the last active device to the daisy chain power input on the new device.

The number of devices that can be daisy chained is limited.

The **maximum** that can ever be daisy chained is **6 devices** in a single chain.

Beyond that the number of switch hops may cause audio problems due to excessive latency and increased clock jitter.

The other limitation is the power supply, if power is also being daisy chained from device to device.

Standalone:

If power is supplied to the first device via a standalone supply, the supplies maximum power output determines the number of devices it can support (assume 4W @ 12V DC per device).

To daisy chain a device to another CDT100:

- Connect an Ethernet cable from the data only port of the CDT100 MKII to one of the ports of the CDT100 MKII to be chained to supply the network information.
- To chain the power, connect the “Link out” connector to the “Link in” connector on the CDT100 MKII to be chained.
- A third unit could be chained by connecting it in the same way to the second unit and so on.

Network Configuration Note:

If the CDT100 MKII units are installed in a networked daisy-chain topology, it is highly recommended to only configure unicast flows from each of the CDT100 MKII devices' Dante transmitters.

The addition of multicast flows along the daisy chain can overwhelm the switches in the chain with unnecessary multicast audio traffic resulting in potential latency and network clock synchronization issues, especially on the units installed at the end of the daisy-chain network segment.

Additionally, if there are a significant number of multicast audio flows configured on the Dante network, it is recommended that the core network switches that interface to the daisy-chained CDT100 network segments be configured with the appropriate IGMP settings to shield the CDT100 MKII chain from unnecessary multi-cast audio traffic.

5.1 – Dante Daisy Chaining - Example 1

Clockaudio Microphones - C012EN RF and Control Devices - TS005

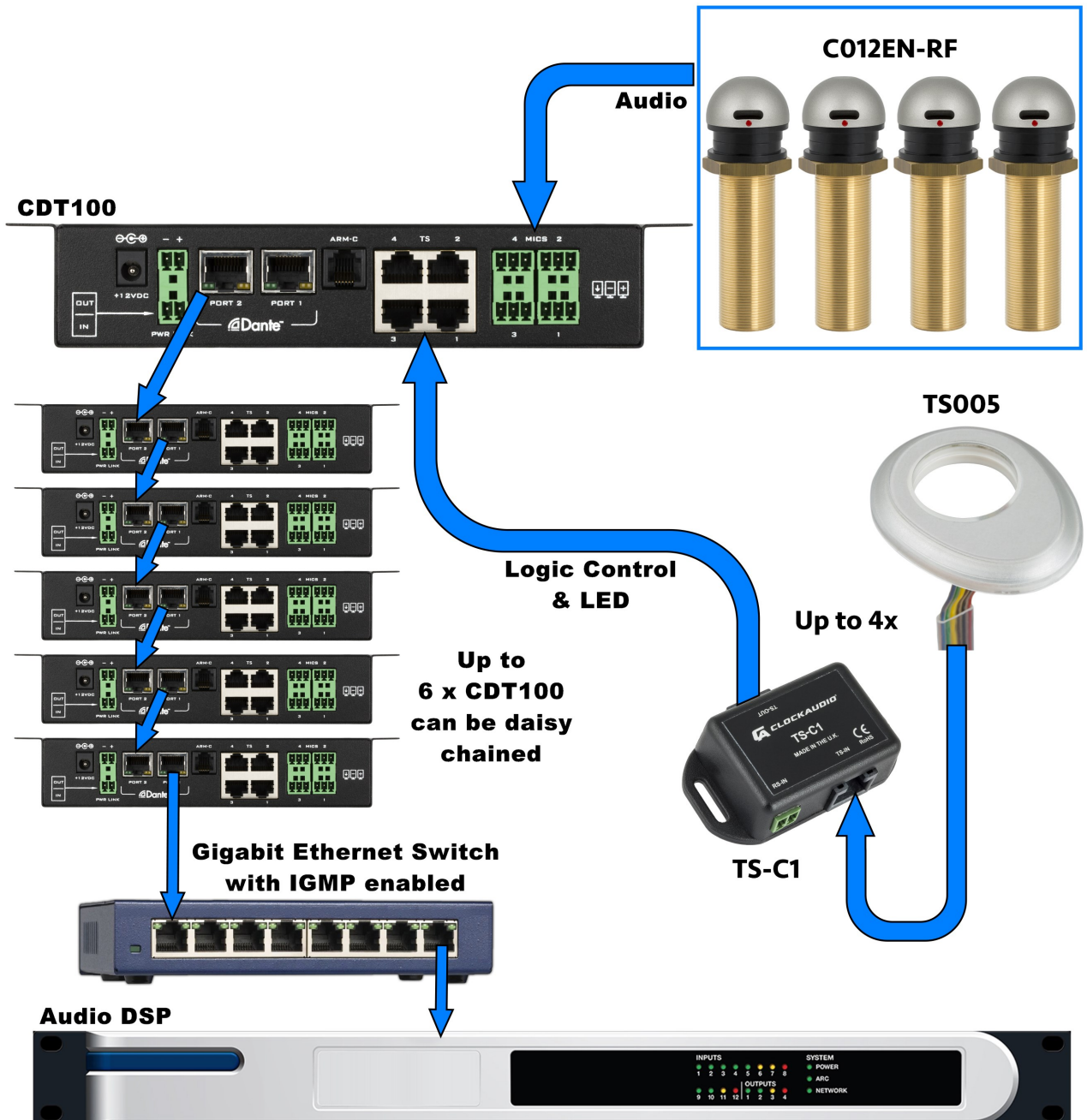

Figure 7 - Daisy Chain and Network Configuration Example

To daisy chain a device to another CDT100:

- Connect an Ethernet cable from the data only port of the CDT 100 to one of the ports of the CDT100 to be chained to supply the network information.
- To chain the power, connect the "Link out" connector to the "Link in" connector on the CDT100 to be chained.
- A third unit could be chained by connecting it in the same way to the second unit and so on.

5.2 – Dante Daisy Chaining - Example 2

Clockaudio Microphones - ARM102N RF and Control Devices - TS003

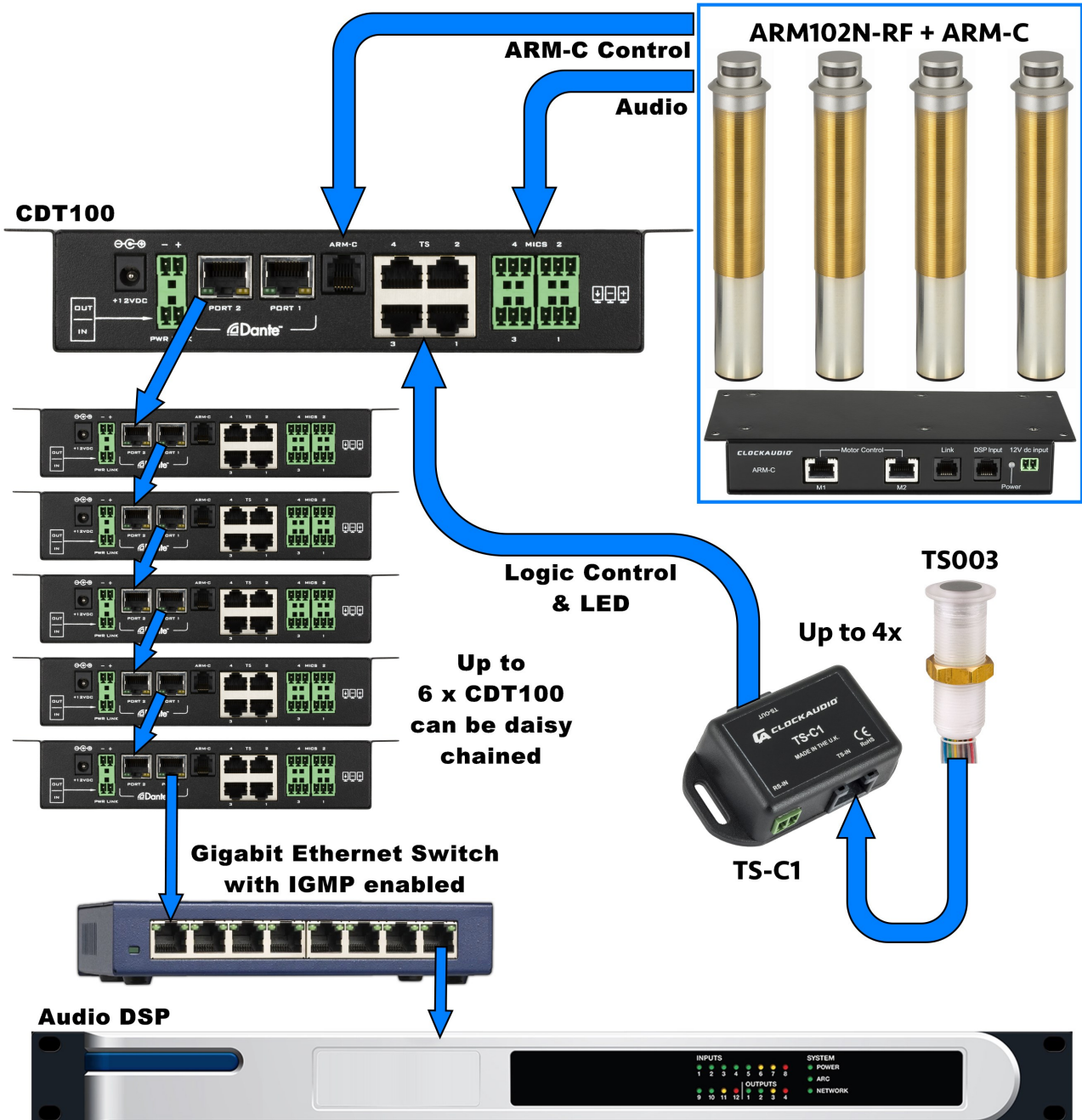

Figure 8 - Daisy Chain and Network Configuration Example

To daisy chain a device to another CDT100:

- Connect an Ethernet cable from the data only port of the CDT100 to one of the ports of the CDT100 to be chained to supply the network information.
- To chain the power, connect the “Link out” connector to the “Link in” connector on the CDT100 to be chained.
- A third unit could be chained by connecting it in the same way to the second unit and so on.

6 – Device Configuration

There are two parts of the device that require software to setup:

1. The audio routing.
2. The configurable features of the device itself.

The audio routing should be carried out using Audinate’s Dante Controller, available for Windows and Mac OS X from the Audinate website www.audinate.com along with instructions on how to use the software and setting up routes on a Dante network.

Dante Controller is a free software application that enables you to route audio and configure devices on a Dante network. With automatic device discovery, one-click signal routing and user-editable device and channel labels.

See the overview link for more details on [Dante audio networking](#).

Features:

- View all Dante-enabled audio devices and their channels on the network.
- View and edit device clock and network settings.
- Route audio between devices, and view the state of existing audio routes.
- Rename devices and channels using your own friendly names.
- Customize the receive latency (latency before playout).
- Save and reapply audio routing presets.
- Edit presets offline, and apply as configurations for new network deployments.
- Change sample rates and clock settings.
- View multicast bandwidth across the network.
- View transmit and receive bandwidth for each device.
- View device performance information, including latency stats, clock stability stats and packet errors.
- View comprehensive, configurable event logs.

6.1 - IP Address Setup

Important Notes:

- When using Dante controller, the CDT100 MKII will be shown using a default device name of CDT100-##### where ‘#####’ is the last six characters of the devices MAC address.
- Failure to correctly configure IP addresses will not allow an CDT100 MKII device to correctly authenticate in the software and while it will show up in Dante Controller. The input and output channels won’t be visible and routing of audio to and from the CDT100 MKII will not be possible.

In order to configure an CDT100 MKII both to set up its internal parameters and also setup audio routing, the PC will need to be able to communicate with it over the network.

While all Dante devices will be discovered regardless of the IP address setup on the PC, communication can only occur if the PC and the device have compatible IP addresses.

By default, CDT100 MKII is set to get a dynamic IP address. As with all Dante devices, if the CDT100 MKII device does not find a DHCP server to retrieve an IP address from, it will give itself an automatic private IP address (APIPA) instead.

An APIPA (link local) is always in the range 169.254.x.y.

To ensure communication, the PC can either be set to get a dynamic IP address, or be given a static IP address in the range 169.254.x.y. The PC may require a restart for the changes to take affect.

Further information on IP setup for an audio system using Dante can be found in the FAQ’s on the Audinate website (<https://www.audinate.com/resources/faqs>).

7 – Recommended microphone placement

The CDT100 features a fixed input gain setting optimized for Clockaudio microphones.

Follow these guidelines for best results:

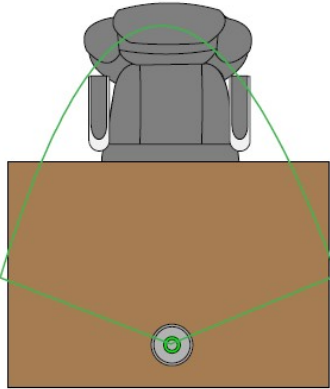

One cardioid microphone per person:
18" - 20" from the edge of the table

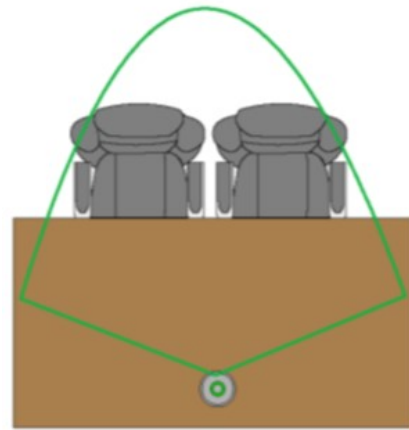

One cardioid microphone per 2 persons:
22" - 24" from the edge of the table

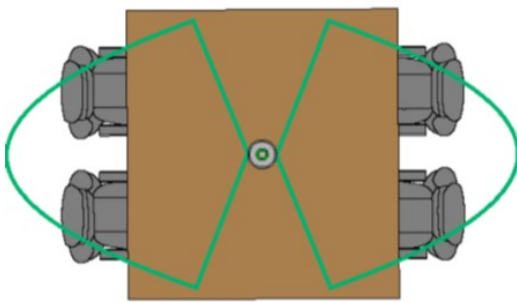

Dual element boundary microphone:
72" maximum table width

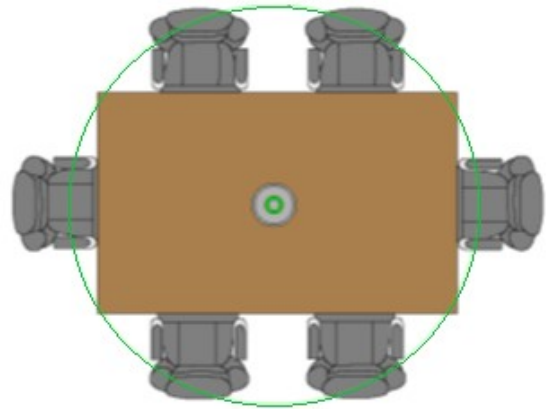

Omni-directional boundary microphone:
48" maximum table width

For more microphone placement recommendations, please contact the Clockaudio technical support department.

8 – Consultants Specifications

The Dante interface unit shall provide four mic analog inputs on the rear panel via 3-pin terminal connectors.

Each of the four inputs shall have a fixed gain of +43dB and a +48V phantom power option shall be provided via software for each input.

The unit shall provide two RJ-45 network connectors to allow Dante Daisy Chaining (DDC) of multiple units.

The internal analog to digital signal conversion shall be performed at 24-bit resolution with a sampling frequency of 48kHz.

The Dante interface unit shall receive power from an external +12V supply.

Four control ports will be available for interfacing with switch buttons and RGB LED.

An interface for motorized microphones shall be included.

The Dante interface unit shall be compatible with third party control systems for flexible control and monitoring in system applications.

The Dante interface shall be compatible with all Clockaudio control devices.

The Dante interface shall be compliant with the RoHS directive.

The Dante interface unit shall be compliant with the EMI/EMC requirements for FCC and CE.

The Dante interface unit shall be the Clockaudio CDT100 MKII.

Audio Inputs		Dante Network	
Input Type:	Balanced and RF filtered	Physical Level:	Standard Ethernet
Gain:	+43dB	Connector:	RJ-45
Input Impedance:	>1.8K ohms	Cable Quality:	CAT 5, CAT 6
Phantom Power:	+48V, software selectable	Transmission Speed:	100 Mbps
		Power Requirements	+12V DC
Audio Performance		Power Consumption	4.9W Max
EIN:	-115dBu	Dimensions	8.32" W x 1.50" H x 4.74" D
System THD+N:	<0.01% at any gain, input signal 3dB below maximum	Weight	1.75 lbs
Frequency Response	20Hz – 20kHz, +/- 1dB	Compliance	FCC CFR 47 Parts 15B ICES-003 CE (EN55022) RoHS
		TS Control Device Inputs	RJ45
		ARM Interface	RJ12

